

Specification :-

1. Extra High Pressure Double Meter Nitrous Oxide Regulator
2. Piston Type Diaphragm to withstand with High Outlet Pressure
3. Inlet Pressure :- (0-400 Bar)
4. Outlet / Working Pressure :- (0-120 Bar )
5. Outlet Connection:- 3/8" - 19 BSP( RH)

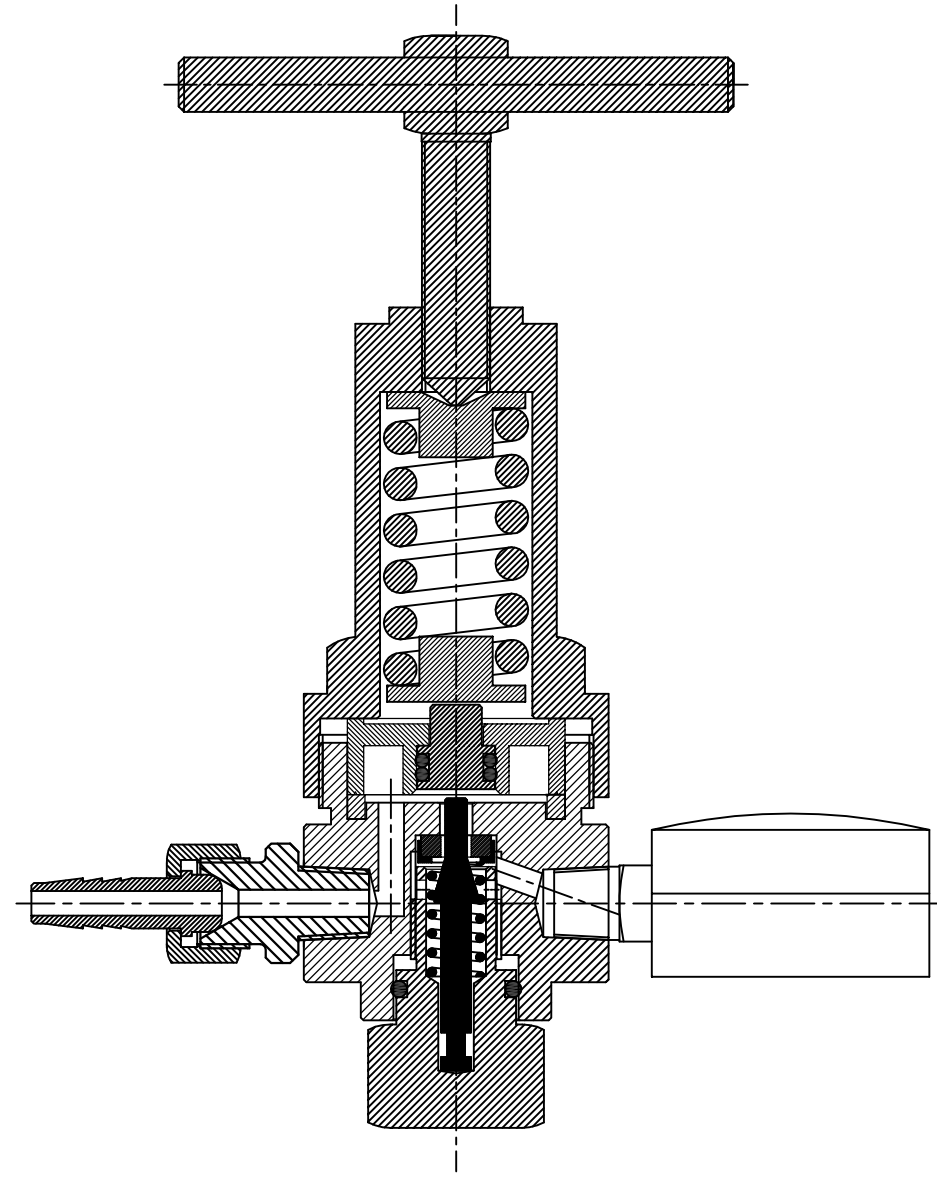
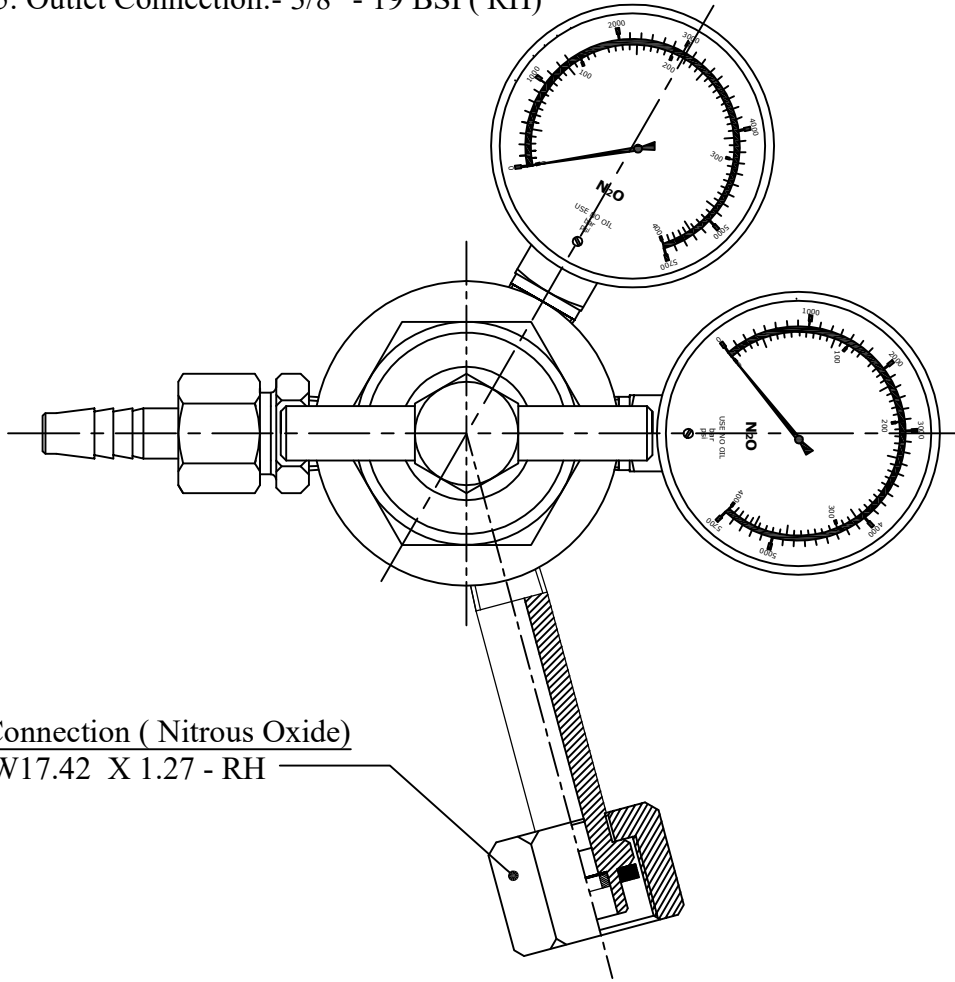

SECTION