

**Specification :-**

1. Two Stage Double Meter Stainless Steel Diaphragm Oxygen Regulator
2. Long Life workability due to Stainless Steel Diaphragm
3. Stainless Steel Diaphragm regulator also used in Hazards Gases
4. Inlet Pressure :- (0-400 Bar)
5. Outlet / Working Pressure (Gradually Pressure Reduce in two stages ) :- (0-14 Bar )
6. Steady Flow Of Gas at the Outlet irrespective of Cylinder Gas Valve
7. Safety Pressure :- ( 15 Bar)
8. Outlet Connection:- 3/8" - 19 BSP( RH)

**Inlet Connection (Oxygen)**  
**G 5/8" A -14 TPI- RH**

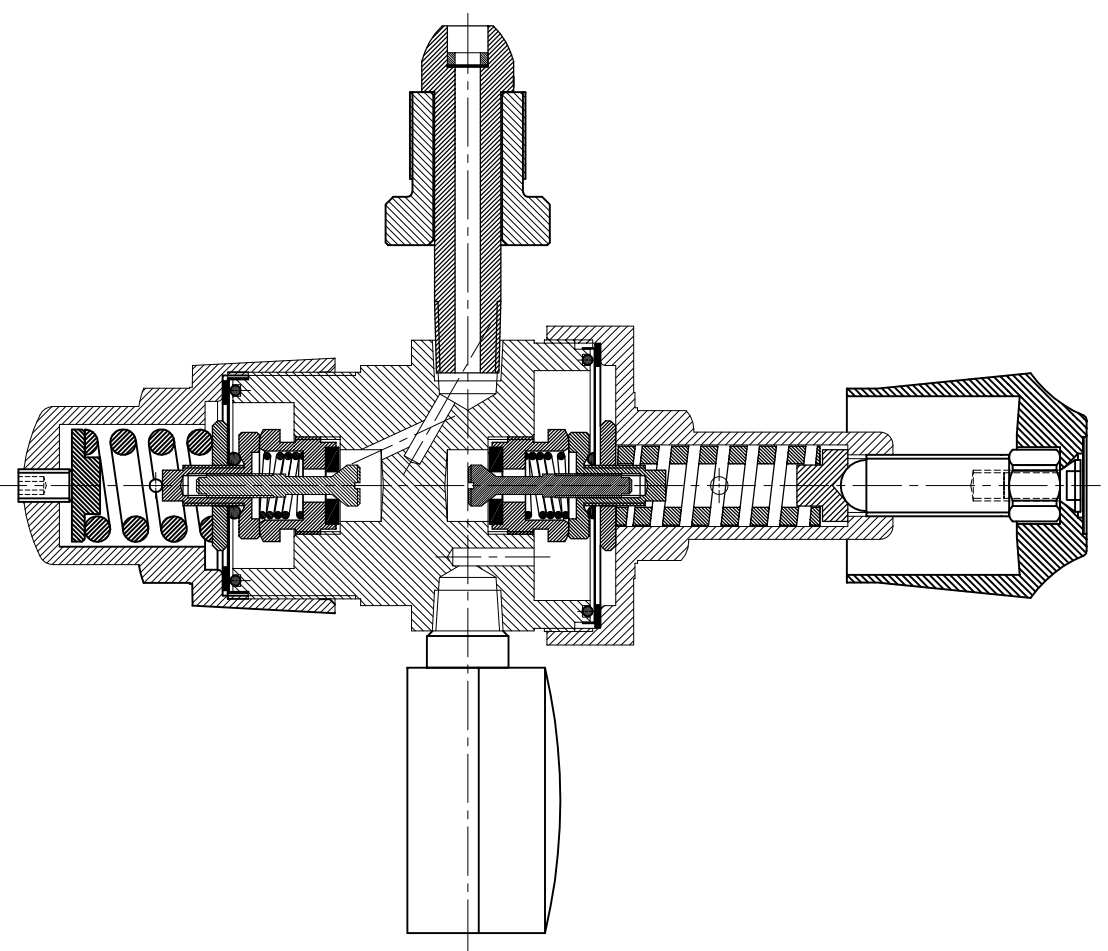
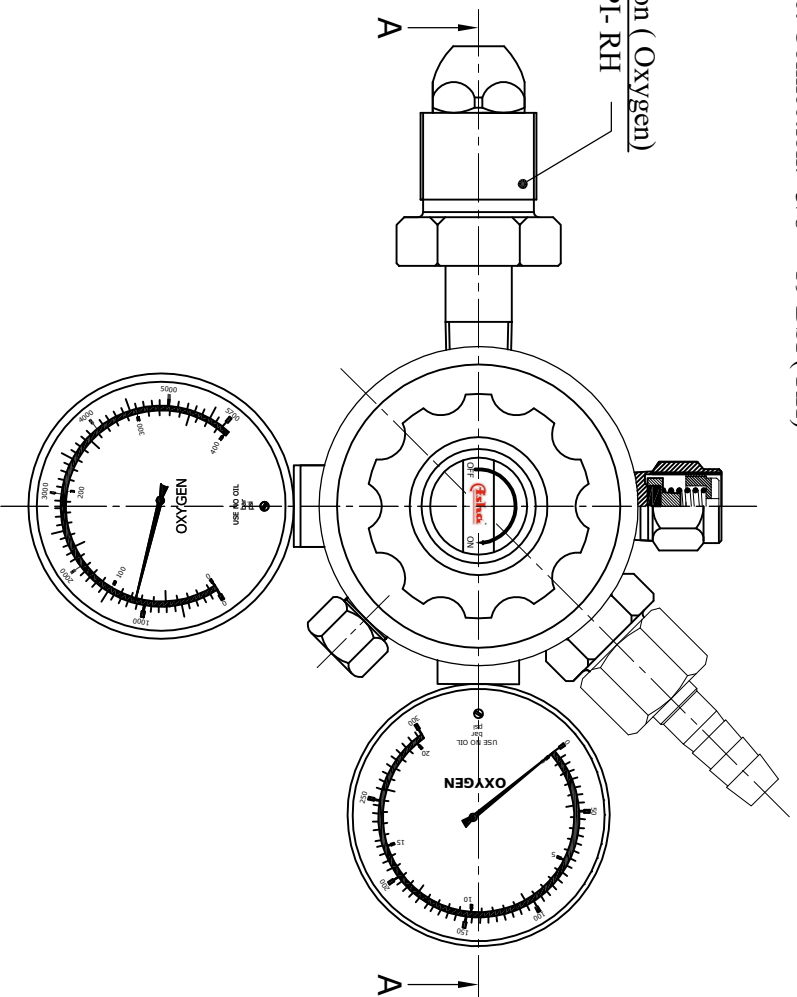

**SECTION A-A**