

Specification :-

1. High Flow Manifold Double Meter Carbon Dioxide Regulator (AOX-14)
2. Inlet Pressure :- (0-400 Bar)
3. Outlet / Working Pressure :- (0-14 Bar)
4. Safety Pressure :- (12 Bar)
5. Outlet Connection:- 3/8" - 19 BSP (RH)

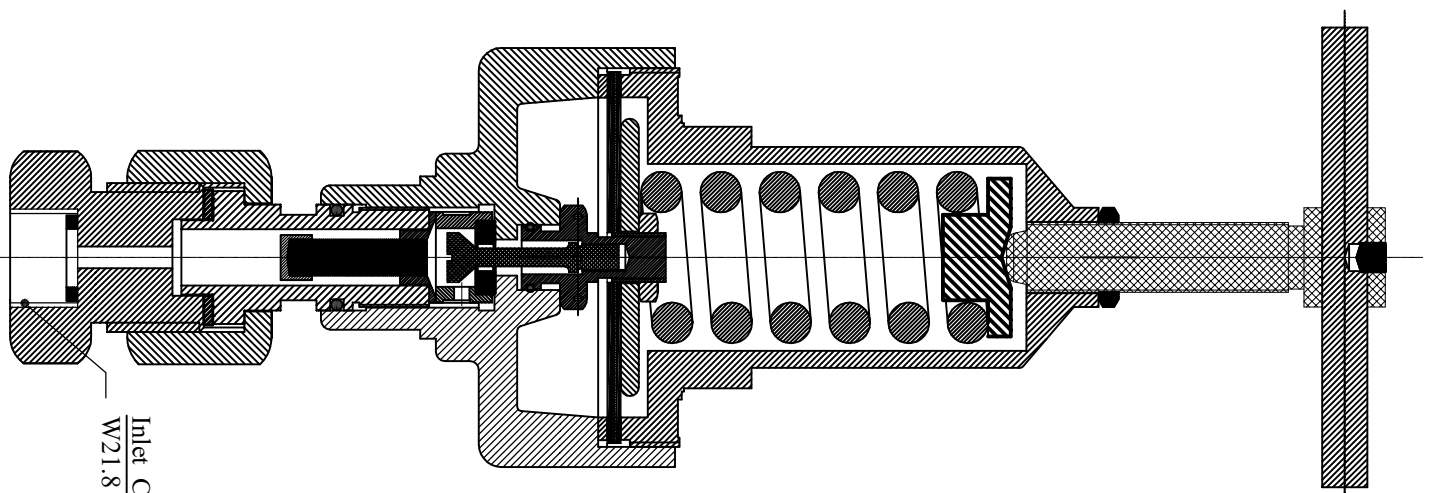
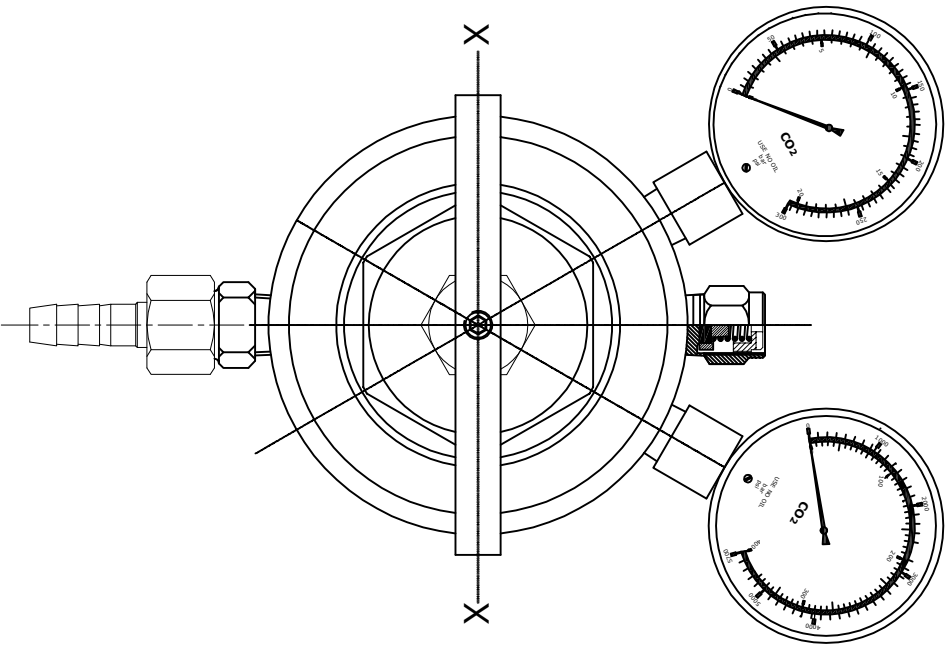

Inlet Connection (Carbon Dioxide)
W21.8 -1.814 (RH)