

Specification :-

1. High Flow Manifold Double Meter Carbon Dioxide Regulator ( AOX-14 )
2. Inlet Pressure :- ( 0-400 Bar )
3. Outlet / Working Pressure :- ( 0-14 Bar )
4. Safety Pressure :- ( 15 Bar )
5. Outlet Connection:- 3/8" - 19 BSP( RH)

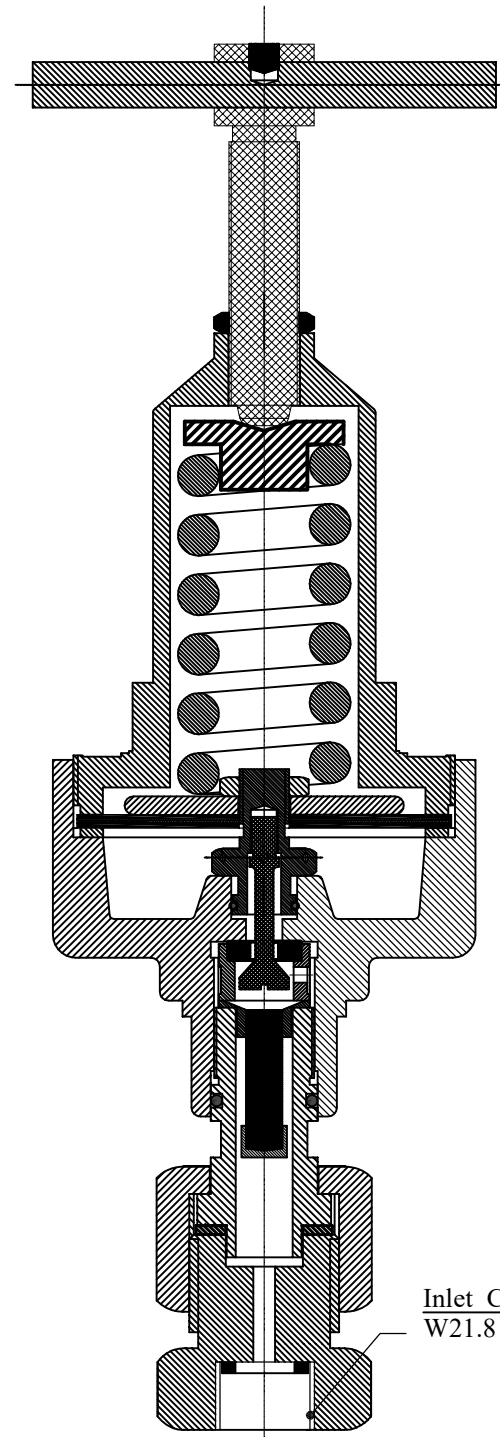
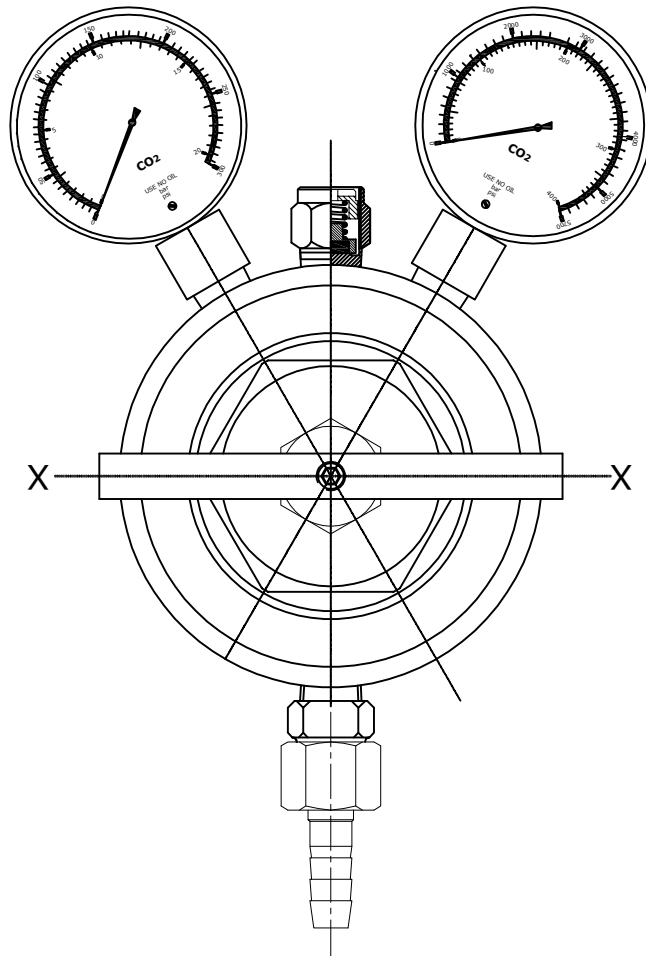

Inlet Connection ( Carbon Dioxide )  
W21.8 -1.814 ( RH)