

Inlet Connection (Air)
G 7/8" -14 TPI- RH

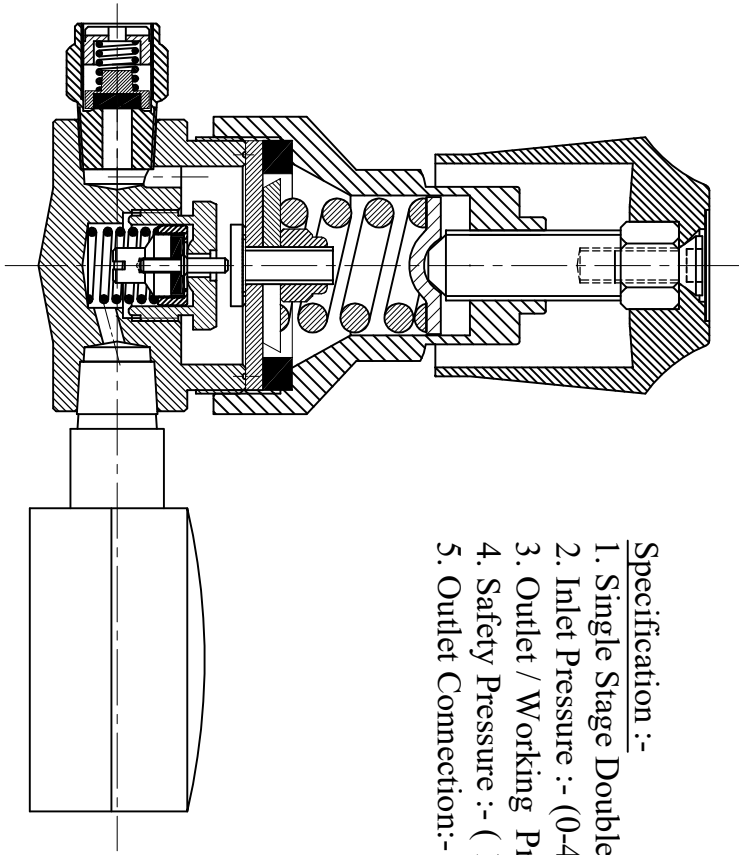

SECTION

Specification :-

1. Single Stage Double Meter Air Regulator
2. Inlet Pressure :- (0-400 Bar)
3. Outlet / Working Pressure :- (0-10 Bar)
4. Safety Pressure :- (12 Bar)
5. Outlet Connection:- 3/8" - 19 BSP(RH)